

# **MAINTENANCE MANUAL**

YAMADA AIR-OPERATED DIAPHRAGM PUMPS

**DP-40-HD** series  
**DP-50-HD** series  
**DP-80-HD** series

## **WARNING**



- For your own safety, be sure to read these procedures carefully before performing maintenance on this product. After reading this document, be sure to keep it handy for future reference.

This maintenance manual covers what you should know about maintenance of the Yamada DP-40-HD series, DP-50-HD series and DP-80-HD series Diaphragm Pumps.

This edition is based on the standards for the March 2010 production run. Remember, the specifications are always subject to change; therefore, some of the information in this edition may not apply to new specifications.

### **Warnings and Cautions**

For safe use of this product, be sure to note the following: In this document, warnings and cautions are indicated by symbols. These symbols are for those who will operate this product and for those who will be nearby, for safe operation and for prevention of personal injury and property damage. The following warning and caution symbols have the meanings described below. Be sure to remember their meanings.



**WARNING :** If you ignore the warning described and operate the product in an improper manner, there is danger of serious bodily injury or death.



**CAUTION :** If you ignore the caution described and operate the product in an improper manner, there is danger of personal injury or property damage.

Furthermore, to indicate the type of danger and damage, the following symbols are also used along with those mentioned above:



This symbol indicates a DON'T, and will be accompanied by an explanation on something you must not do.



This symbol indicates a DO, and will be accompanied by instructions on something you must do in a certain situation.

## **WARNING**



- Before starting maintenance work, cut off the feed air and clean the pump. If air pressure or residue remain in the pump, there is danger of explosion, or possible poisoning resulting in serious injury or death if chemicals adhere to the skin or are accidentally swallowed. (For details on cleaning the pump, refer to Chapter 6 of the operating manual.)
- When replacing parts, be sure to use the recommended genuine parts or Equivalents. Use of other parts may cause a malfunction of the product. (Refer to Exploded View and Reminder to order correct item on the separate sheets.)

## **CAUTION**



- When it is instructed that special tools must be used, be sure to use the specified tools. Otherwise, the pump may be damaged.
- Refer to 10.1 "Specifications" in the Operating Manual. Also, remember that the pump is heavy, and extreme care must be taken when lifting it.

# Table of Contents

## ·Warnings and Cautions

## ·Table of Contents

<b>1. Principles of operation</b> .....	1
<b>2. Tools, etc.</b>	
2.1 General tools .....	1
2.2 Special tools .....	1
2.3 Misc. ....	1
<b>3. Ordering Replacement parts</b> .....	1
<b>4. Balls and Valve seats</b>	
4.1 Removal	
■BA_, BS_, BF_ types.....	2
■DP-40 BP_-HD type .....	3
■DP-50 BP_-HD·BV_-HD, DP-80 BP_-HD types .....	4
4.2 Inspection .....	5
4.3 Installation .....	5
<b>5. Diaphragm, Center rod and Center bushing</b>	
5.1 Removal	
■BA_, BS_, BF_ types.....	6
■BP_, BV_ types.....	6
5.2 Inspection .....	7
5.3 Installation	
■B_C, B_N, B_E, B_V, B_H, B_S types .....	7
■B_T type .....	8
<b>6. Throat bearing and Pilot valve assembly</b>	
6.1 Removal .....	9
6.2 Inspection .....	9
6.3 Installation .....	9
<b>7. Valve Body Assembly</b>	
7.1 Removal .....	10
7.2 Inspection .....	11
7.3 Installation .....	11
<b>8. Valve switcher</b>	
8.1 Removal .....	12
8.2 Inspection .....	12
8.3 Installation .....	12
<b>9. Retightens of Tie rods</b> .....	13

## 1. Principles of operation

There are two diaphragms fixed to the center rod, one at each end. When compressed air is supplied to air chamber b (right side, see Fig. 1.1), the center rod moves to the right, the material in material chamber B is pushed out, and at the same time material is sucked into material chamber A.

When the center rod is moved full-stroke to the right, the air switch valve is switched, compressed air is sent to air chamber a (left side, see Fig.1.2), and the center rod moves to the left. The material in material chamber A is pushed out, and at the same time material is sucked into material chamber B.

Through repetition of this operation, material is repeatedly taken in and discharged out.

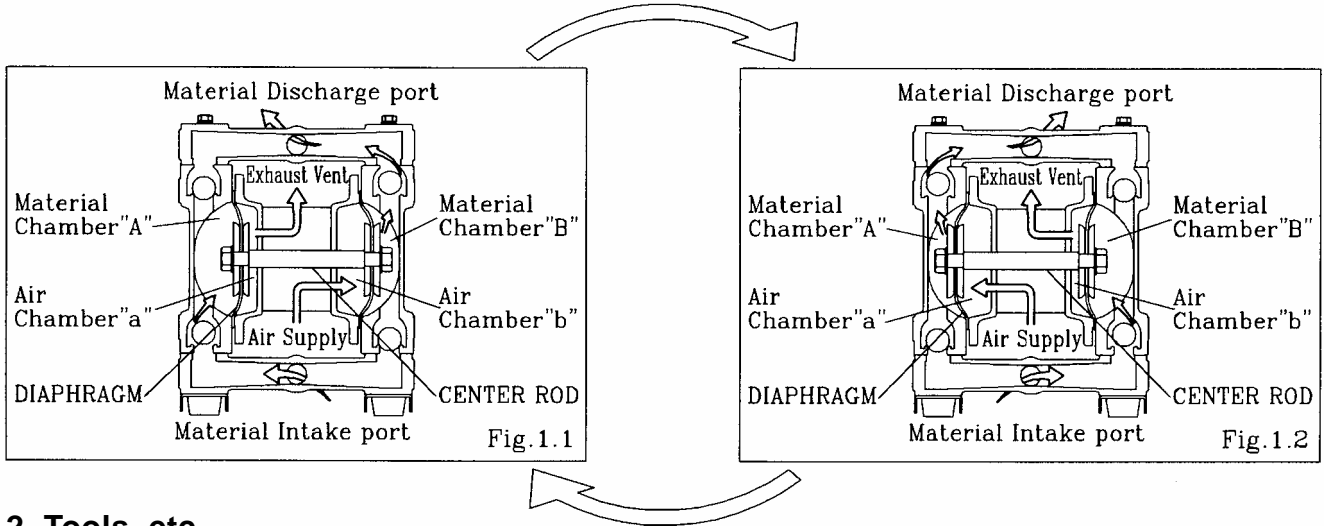

## 2. Tools, etc.

### 2.1 General tools

- Socket wrenches 13mm, 17mm, 19mm (except with the DP-40 BP\_-HD), 24mm (BA\_, BS\_, BF\_)
- Hexagonal box wrenches 5mm, 6mm
- Small crowbars 2 (B\_C, B\_N, B\_E, B\_V)
- Open-end wrenches 17mm (DP-40 BP\_-HD), 19mm (BA\_, BS\_, BF\_), 24mm (BA\_, BS\_, BF\_)
- Phillips-head screw driver

### 2.2 Special tools

- PP wrench (sold separately)  
Purpose: Removing the center disk of BP\_ and BV\_ types

- Socket for a guide (sold separately)  
Purpose: Removing the throat bearing

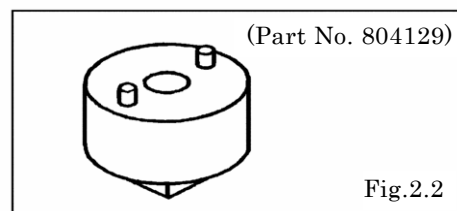
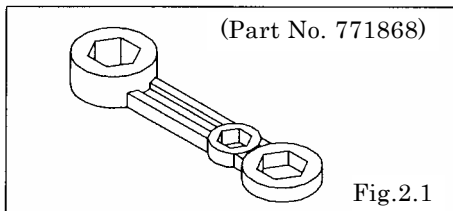

### 2.3 Misc.

- Assembly oil Turbine oil none addition class 1 (equivalent ISO VG32 grade)
- Nuts M16 X 1.5
- Thread locker
- Grease Urea grease grade (NLGI) No. 2  
Shell Alvania Grease S1

## 3. Ordering Replacement parts

For accurate and speedy shipment of parts, be sure to order the right parts for your model to distributor. Indicate the part numbers, descriptions, and quantities.

## 4. Balls and Valve seats

### 4.1 Removal

#### ■ BA\_, BS\_, BF\_ types

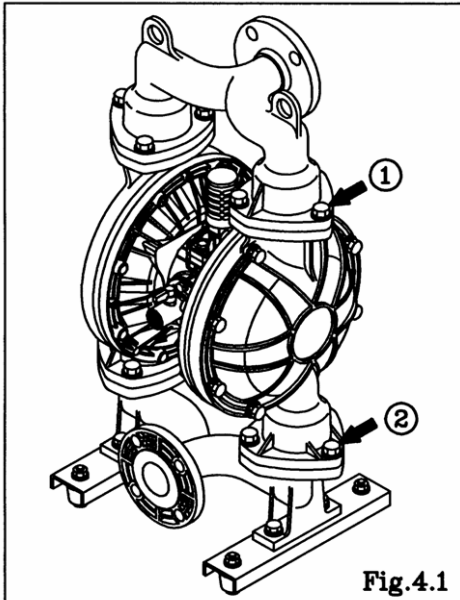

- Remove the 6 (8 on the DP-80-HD) retainer bolts "1" from the out manifold, and remove the out manifold. [Fig.4.1]

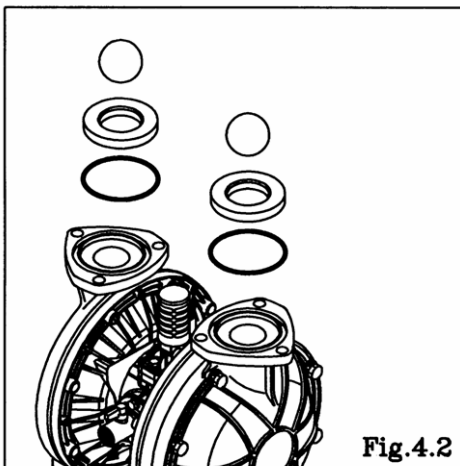

- Remove the ball, valve seat and O ring. [Fig.4.2]

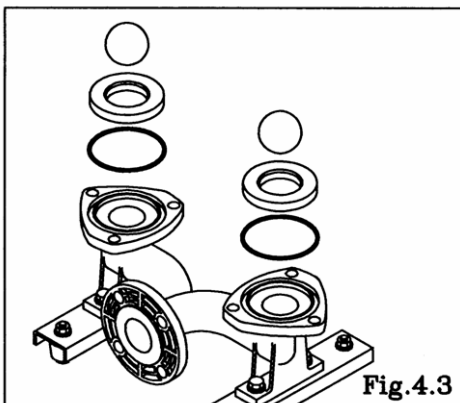

- Remove the 6 (8 on the DP-80-HD) retainer bolts "2" from the in manifold, and remove the in manifold. [Fig.4.1]
- Remove the ball, valve seat and O ring. [Fig.4.3]

## ■DP-40 BP\_-HD type

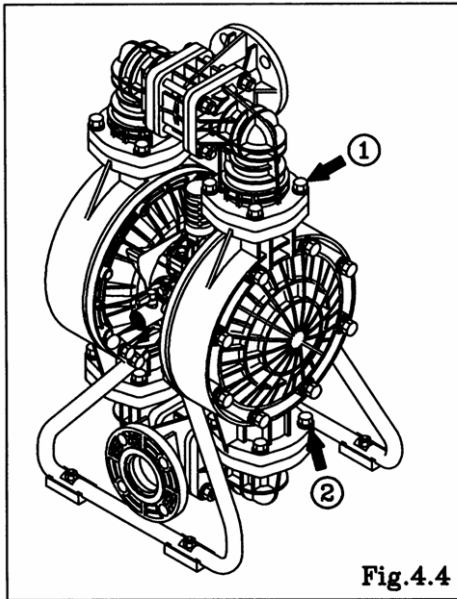

- Remove the 8 retainer bolts "1" from the out manifold, and remove the out manifold. [Fig.4.4]

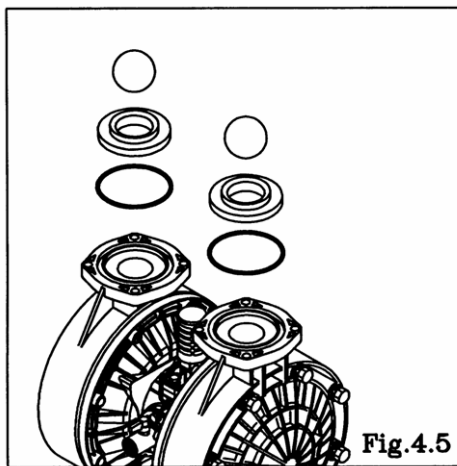

- Remove the ball, valve seat and O ring. [Fig.4.5]

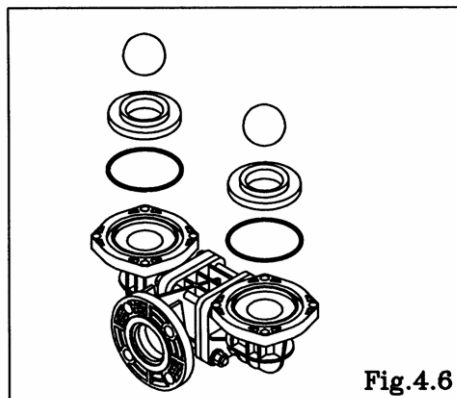

- Remove the 8 retainer bolts "2" from the in manifold, and remove the in manifold. [Fig.4.4]
- Remove the ball, valve seat and O ring. [Fig.4.6]

■ DP-50 BP\_-HD-BV\_-HD, DP-80 BP\_-HD types

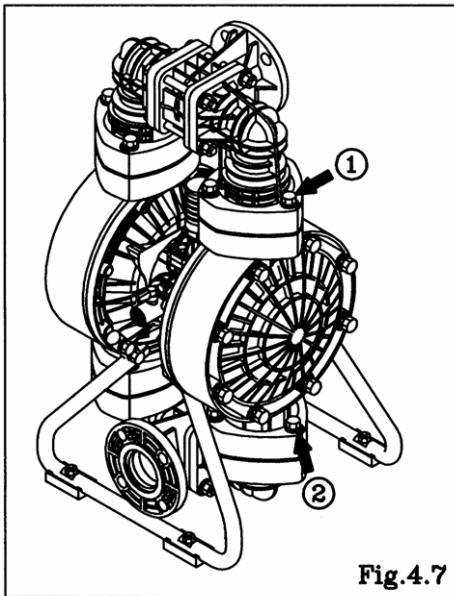

- Remove the 6 (8 on the DP-80-HD) retainer bolts "1" from the out manifold, and remove the protector and out manifold. [Fig.4.7]

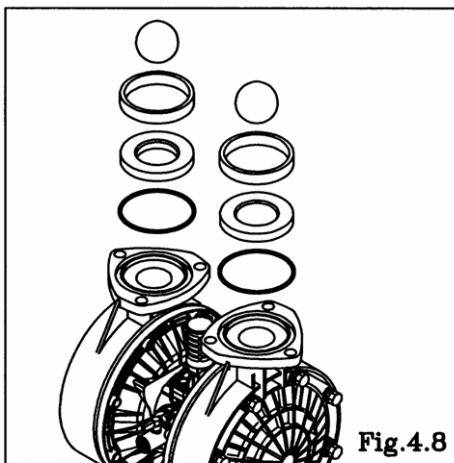

- Remove the ball, valve guide (only DP-80-HD), valve seat and O ring. [Fig.4.8]

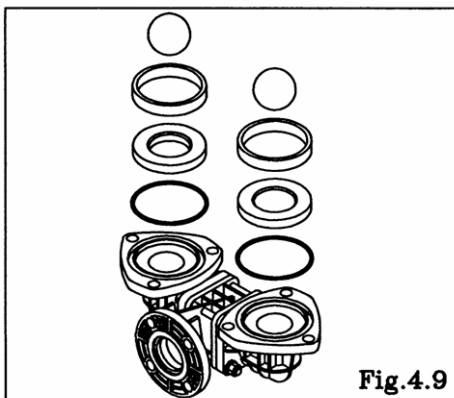

- Remove the 6 (8 on the DP-80-HD) retainer bolts "2" from the in manifold, and remove the protector and in manifold. [Fig.4.7]
- Remove the ball, valve guide (only DP-80-HD), valve seat and O ring. [Fig.4.9]

## 4.2 Inspection

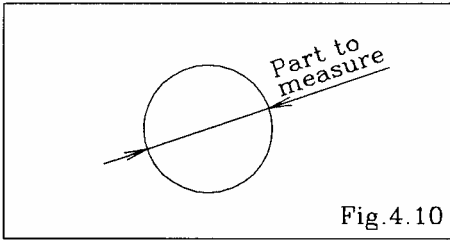

- Ball [Fig.4.10]

Measure the outside diameter, and if it is outside the usable range, replace the ball.

Usable range of ball

DP-40-HD	Sø1.772 ~ Sø2.028 in {Sø45.0 ~ Sø51.5 mm}
DP-50-HD	Sø2.232 ~ Sø2.555 in {Sø56.7 ~ Sø64.9 mm}
DP-80-HD	Sø3.189 ~ Sø3.650 in {Sø81.0 ~ Sø92.7 mm}

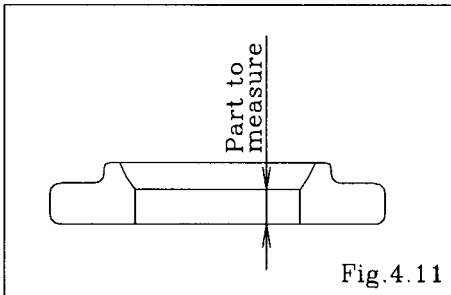

- Valve seat [Fig.4.11]

Measure the dimension shown at left, and if it is outside the usable range, replace the seat.

Usable range of valve seat

	B_C, B_N, B_E B_V, B_H, B_S	B_T
DP-40-HD	0.181 ~ 0.453 in {4.6 ~ 11.5 mm}	0.067 ~ 0.161 in {1.7 ~ 4.1 mm}
DP-50-HD	0.197 ~ 0.492 in	
DP-80-HD	{5.0 ~ 12.5 mm}	

- O ring (other than PTFE)

If O ring is worn out or cracked, replace it.

## 4.3 Installation

For installation, see [Exploded View] on the separate sheet and install in the reverse order of disassembly.

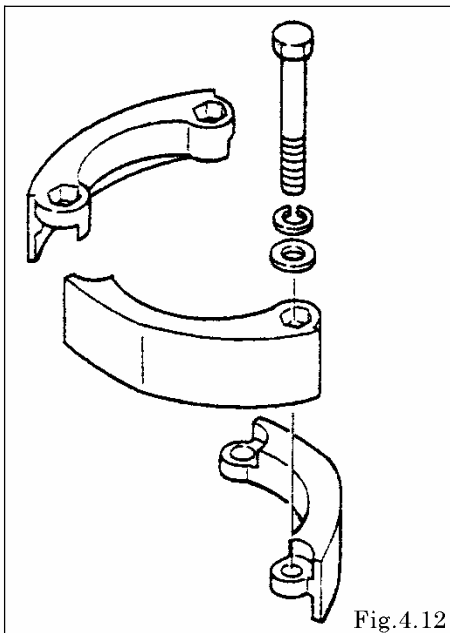

Tightening torque for manifold retainer bolts

15 ft-lbf {20 N-m}		
DP-50-HD	BP_, BV_	18 ft-lbf {25 N-m}
DP-80-HD	BP_	

<NOTE>

- Make sure there is no dust on the seal surface and the seal is not damaged.
- Match the convex and concave parts of the protector.

[Fig.4.12] (DP-50 BP\_-HD·BV\_-HD, DP-80 BP\_-HD)



## 5. Diaphragm, Center rod and Center bushing

### 5.1 Removal

#### ■BA\_, BS\_, BF\_ types

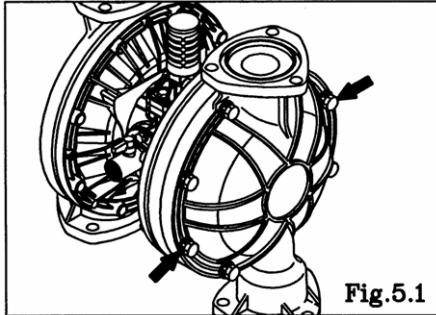

- Remove the ball and valve seat etc.(see [ 4.1 Removal BA\_, BS\_, BF\_ types] on P.2)
- Remove the 16 (24 on the DP-80-HD) retainer bolts from the out chamber, and remove the out chamber. [Fig.5.1]

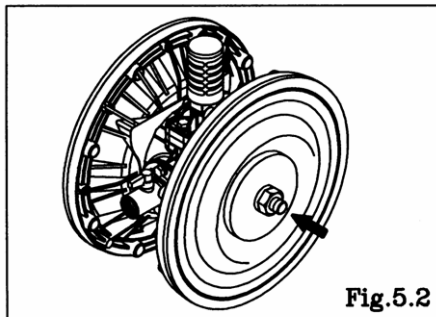

- Remove the nut on one side of the center rod. Then, remove the coned disk spring, center disk, diaphragm and center bushing on the same side. [Fig.5.2]
- Pull out the other center disk, diaphragm and center bushing together with the center rod from the main body.

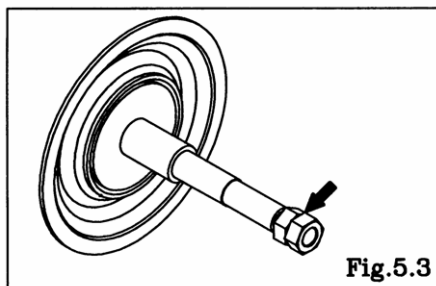

- Remove the other nut using the double-nut method. Then, remove the coned disk spring, center disk, diaphragm and center bushing. [Fig.5.3]

#### <NOTE>

- Be careful not to damage the center rod and center bushing.

#### ■BP\_, BV\_ types

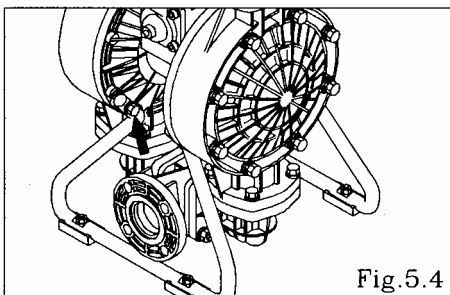

- Remove the ball etc.(see [ 4.1 Removal BP\_, BV\_ types]on P.3-4)
- Remove the 8 (4 on the DP-40-HD) retainer bolts from the stand body, and remove the stand body. [Fig.5.4]

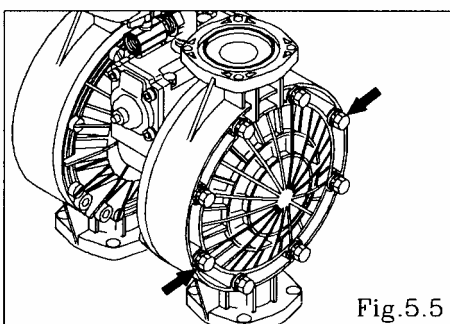

- Remove the 16 (24 on the NDP-80-HD) retainer bolts from the out chamber, and remove the out chamber. [Fig.5.5]

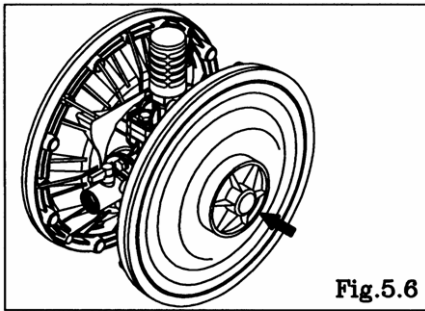

Fig.5.6

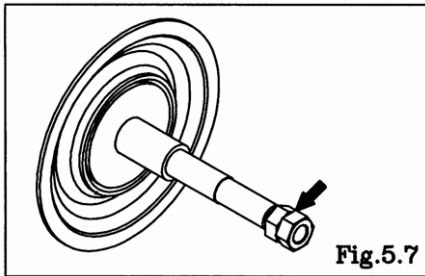

Fig.5.7

- Remove the center disk from one side using the PP wrench (special tool: Part No. 771868). [Fig.5.6]
- Then, remove the diaphragm, center disk inside and center bushing on the same side.  
Pull out the other diaphragm, center disk inside and center bushing together with the center rod from the main body.

- Fix a double nut to one end of the center rod and take the diaphragm and center disk off the oppsite end. [Fig.5.7]

<NOTE>

- Be careful not to damage the center rod and center bushing.

## 5.2 Inspection

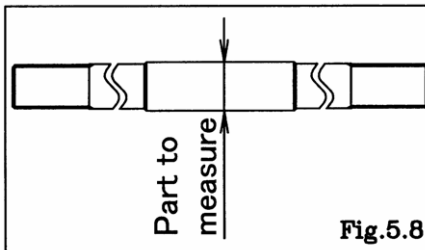

Fig.5.8

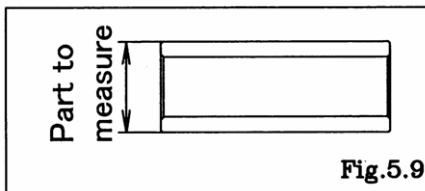

Fig.5.9

- Diaphragm  
If the diaphragm is worn out or damaged, replace it.

Guideline of diaphragm life

CR, NBR, EPDM	10,000,000 cycle
FKM	2,500,000 cycle
PTFE	3,000,000 cycle
TPEE, TPO	15,000,000 cycle

(When used with clean water at room temperature)

- Center rod [Fig.5.8]  
Measure the diameter, and if it is outside the usable range, replace the rod.

Usable range of center rod

$\varnothing 0.9815 \sim \varnothing 0.9843$  in  $\{\varnothing 24.93 \sim \varnothing 25.00$  mm}

- Center bushing [Fig.5.9]  
Measure the diameter, and if it is outside the usable range, replace the rod.

## 5.3 Installation

### ■ B\_C, B\_N, B\_E, B\_V, B\_H, B\_S types

For installation, see [Exploded View] on the separate sheet and install in the reverse order of disassembly.

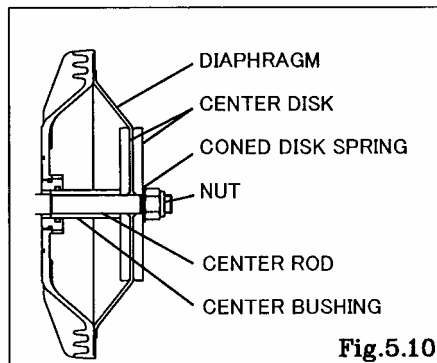

Fig.5.10

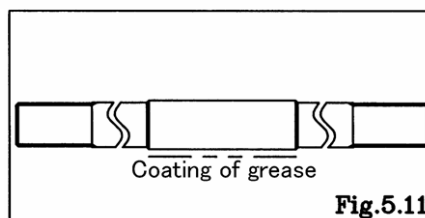

Fig.5.11

- Apply assembly grease(urea) to the center rod, and insert it into the main body. [Fig.5.11]
- Apply assembly grease(urea) to the outer surface of the center bushing and then attach it on the center rod.
- Keep the marking "OUTSIDE" to liquid end for CR, NBR, EPDM, FKM diaphragms.  
Keep the convex side to the outside for TPEE, TPO diaphragms. [Fig.5.10]
- Tighten the center disk using the PP wrench(special tool: Part No.771868) for the BP\_, BV\_ types. Apply proper Thread locker to the thread of center disk.

(No coned disk springs and nuts are needed.)

Tightening torque for center rod

BA_, BS_, BF_	43 ft-lbf {60 N-m}
BP_, BV_	36 ft-lbf {50 N-m}

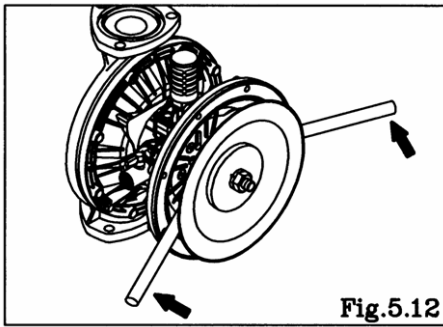

- Draw the center disk to one side (exclude B\_H, B\_S types cf. Fig.5.10). and install the out chamber. tighten the bolts temporarily.
- Grip the inside center disk using crowbars and draw it to the opposite side, then turn the diaphragm over. (exclude B\_H, B\_S types) [Fig.5.12, 5.13]
- And install the out chamber. Tighten the bolts temporarily.
- After installation of the out chambers on both sides, place the pump on a flat surface and stand the pump upright for further assembly.

Tightening torque for out chamber.

BA_, BS_, BF_	29 ft-lbf {40 N-m}
BP_, BV_	26 ft-lbf {35 N-m}

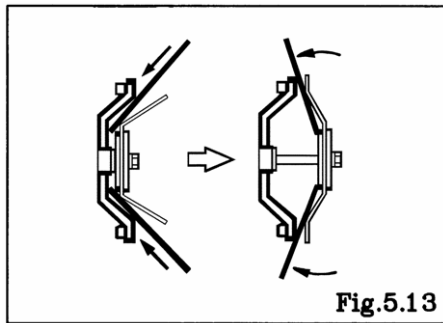

<NOTE>

- Make sure there is no dust on the seal surface in order to prevent seal damaged.
- Be careful not to damage the R portion of the air chamber using a crowbar, etc.
- Tighten the bolts gradually in a diagonal sequence with even torque.

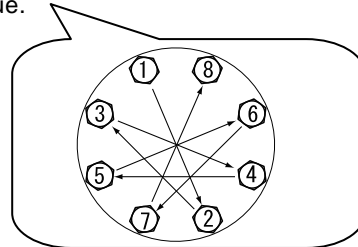

## ■ B\_T type

For installation, see [Exploded View] on the separate sheet and install in the reverse order of disassembly.

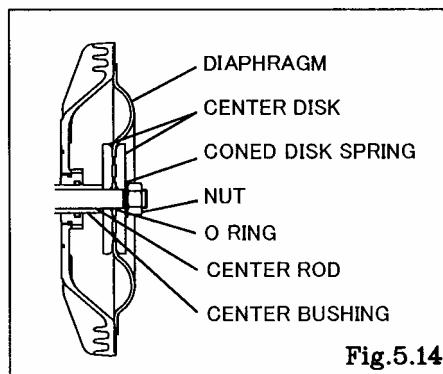

- Apply assembly grease(urea) to the center rod, and insert it into the main body. [Fig.5.11]
- Apply assembly grease (urea) to the outer surface of the center bushing and then attach it to the center rod.
- Keep the convex side to the outside (cf. Fig.5.14).
- Put the O rings to both sides of the diaphragm. (cf. Fig.5.14)
- Tighten the center disk using the PP wrench(special tool: Part No. 771868) for the BPT, BVT types. Apply proper Thread locker to the thread of center disk. (No coned disk springs and nuts are needed.)

Tightening torque for center rod

BAT, BST, BFT	43 ft-lbf {60 N-m}
BPT, BVT	36 ft-lbf {50 N-m}

- Tighten the out chamber temporarily at first. After installation of the out chambers on both sides, place the pump on a flat surface and stand the pump upright for further assembly.

Tightening torque for out chamber

BAT, BST, BFT	29 ft-lbf {40 N-m}
BPT, BVT	26 ft-lbf {35 N-m}

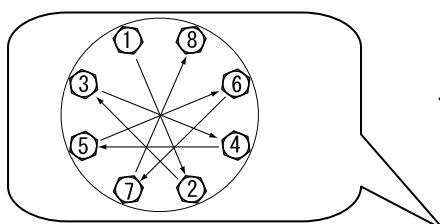

<NOTE>

- Make sure there is no dust on the seal surface in order to prevent seal damaged.
- Replace the PTFE O ring by new one.
- Tighten the bolts gradually in a diagonal sequence with even torque.

## 6. Throat bearing and Pilot valve assembly

### 6.1 Removal

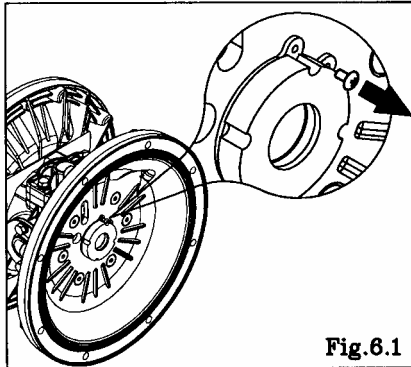

- Remove the diaphragm and center rod (see [5.1 Removal] on P.6-7).
- Unscrew the tapping screws with a Phillips-head screw driver. [Fig.6.1]
- Remove the throat bearing using a special tool (804129). [Fig.6.1]

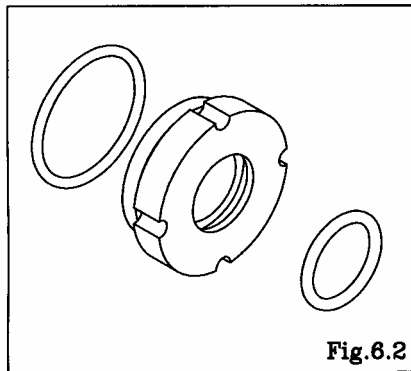

- Remove the O rings from the throat bearing. [Fig.6.2]

### 6.2 Inspection

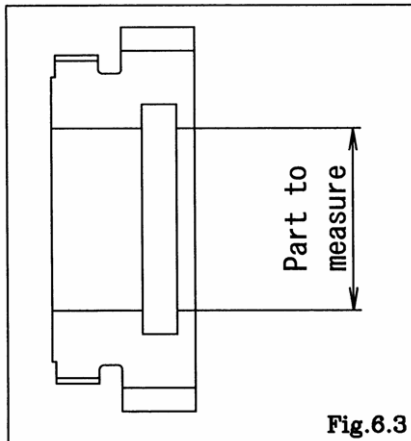

- Throat bearing [Fig.6.3]  
Measure the inside diameter, and if it is outside the usable range, replace the throat bearing

Usable range of throat bearing

$\varnothing 0.9859 \sim \varnothing 0.9894$  in  $\{\varnothing 25.04 \sim \varnothing 25.13 \text{ mm}\}$

- O ring  
If the O ring is worn out or cracked, replace it.

### 6.3 Installation

For installation, see [Exploded View] on the separate sheet and install in the reverse order of disassembly.

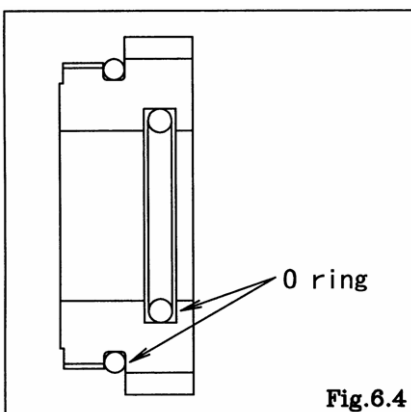

- Screw the throat bearing all the way into the air chamber and then back it to align the bolt holes.
- Tighten the tapping screws.

<NOTE>

- Make sure there is no dust on the seal surface and the seal is not damaged.
- Inner O ring grease(urea) can be applied fully.

## 7. Valve Body Assembly

### 7.1 Removal

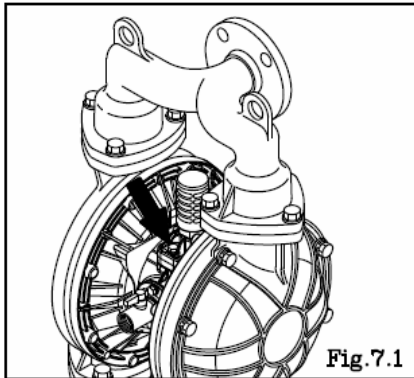

- Remove the silencer.
- Remove the 2 retainer bolts from the valve body, and remove the valve body. [Fig.7.1]
- Disconnect in the same way both up and down.

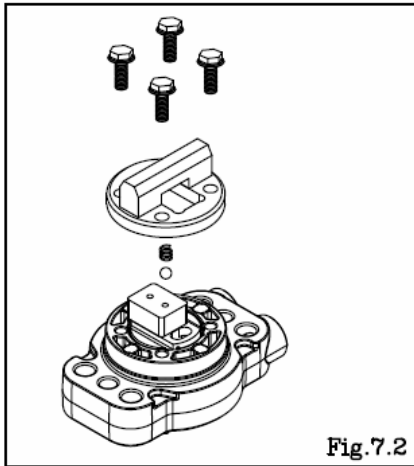

- Unscrew all four screws securing the guide plate and remove the block, spring and ball. [Fig.7.2]

#### <NOTE>

- The ball is very small. Be careful handling it.
- Use self-tapping bolts to attach the new valve body. (Female threads will be formed)

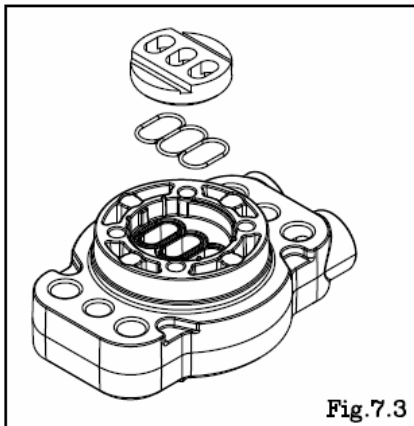

- Remove the valve seat and gasket. [Fig.7.3]

## 7.2 Inspection

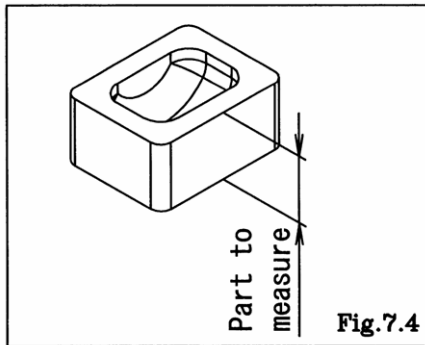

- Block [Fig.7.4]

Measure the thickness and if it is not within the permissible range, replace with a new one. Also, replace the block if its sliding surface is worn out.

Usable range of seal ring

0.4488 in~0.4527 in { 11.4 mm~11.55 mm }

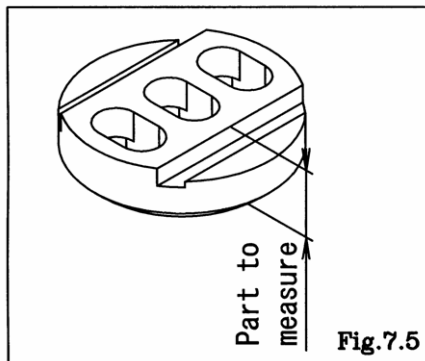

- Valve seat [Fig.7.5]

Measure the thickness and if it is not within the permissible range, replace with a new one. Also, replace the block if its sliding surface is worn out.

Usable range of seal ring

0.3444 in~0.3543 in { 8.75 mm~9.00 mm }

- Gasket, Ball

If the Gasket and Ball are worn out or cracked, replace them.

<NOTE>

- Apply enough grease(urea) to the spring and ball.

## 7.3 Installation

For installation, see [Exploded View] on the separate sheet and install in the reverse order of disassembly.

## 8. Valve switcher

### 8.1 Removal

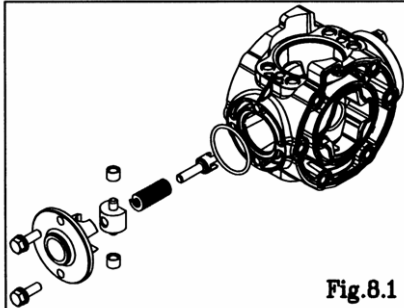

- Remove the diaphragm and center rod. (see [5.1 Removal] on P.6-7)
- Remove the 12 retainer bolts from the air chamber, and remove the air chamber.
- Remove the valve body assembly. (see [7.1 Removal] on P.10)
- Unscrew the two bolts on each retainer and then remove both retainers.

<NOTE>

- Be very careful when removing the retainers. The spring may pop out.
- Remove the spring retainers, bushings, springs, trip arms and O rings from each side.

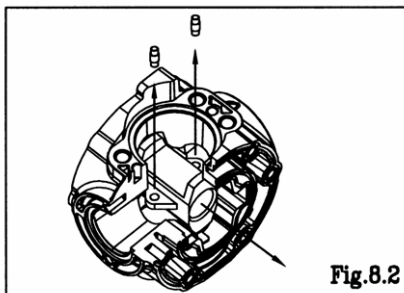

<NOTE>

- Be careful not to drop the trip arms when removing them.
- Pull out the pins in the direction of the arrow.
- Remove the valve switcher in the direction of the arrow.

### 8.2 Inspection

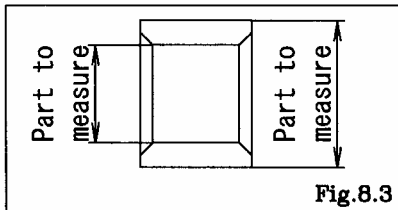

- Bushing [Fig.8.3]

Measure the inside diameter Outside diameter, and if it is outside the usable range, replace the throat bearing.

Usable range of sleeve

Inside diameter	0.2952 in~0.3188 in { 7.5 mm~8.1 mm }
Outside diameter	0.45270.4724 { 11.5 mm~12 mm }

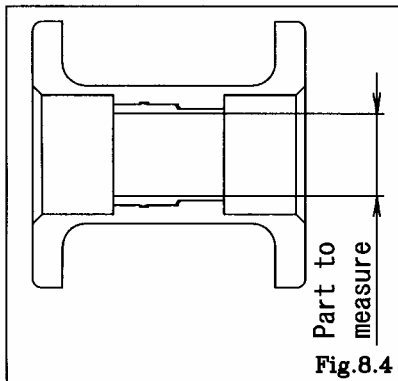

- Valve switcher [Fig.8.4]

Measure the inside diameter, and if it is outside the usable range, replace the throat bearing.

Usable range of sleeve

0.7007~0.7145 in { 17.80 mm~18.15 mm }
--

### 8.3 Installation

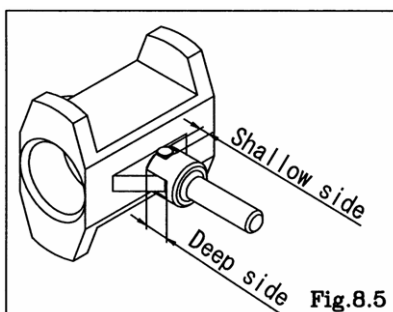

Tightening torque for air chamber retainer bolts

15 ft-lbf {20 N-m}
--------------------

- Attach the trip arm in a way that the valve switcher and pin fit in each groove on the trip arm. [Fig.8.5]

<NOTE>

- Use grease (alvania) to set the pins.

## 9. Retightening of Tie rods

### ■ Plastic type

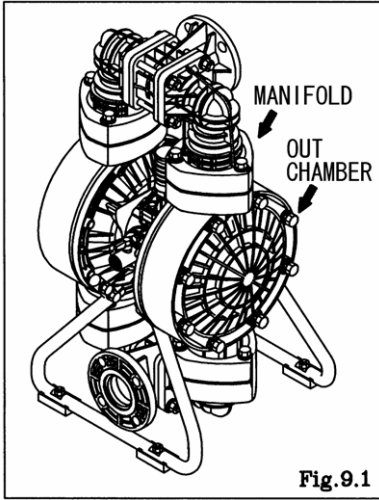

- All bolts should be retorqued:
  - (1) Right before start up.
  - (2) There are any leaks of material on daily inspecting a pump.

		Retain bolts for the out chamber	Retain bolts for the manifold
DP-40.50.80-HD	BP_	26 ft-lbf {35 N-m}	15 ft-lbf {20 N-m}
DP-50-HD	BV_		

<NOTE>

- Retighten the Out chamber and then the manifold in this order. [Fig.9.1]
- Tighten the bolts in the order shown.

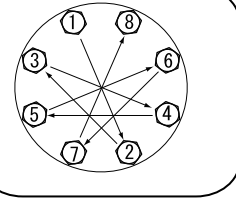

### ■ Metal type

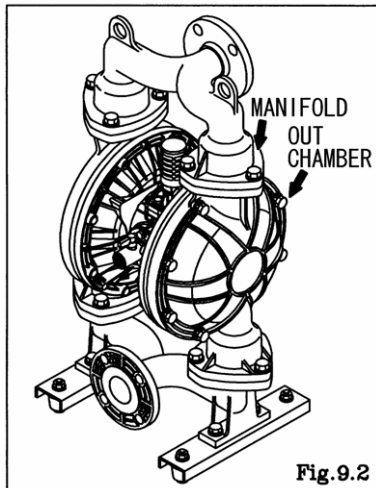

- All bolts should be retorqued:
  - (1) Right before start up.
  - (2) There are any leaks of material on daily inspecting a pump.

		Retain bolts for the out chamber	Retain bolts for the manifold
DP-40.50.80-HD	BA_ BS_ BF_	29 ft-lbf {40 N-m}	15 ft-lbf {20 N-m}

<NOTE>

- Retighten the Out chamber and then the manifold in this order. [Fig.9.2]
- Tighten the bolts in the order shown.

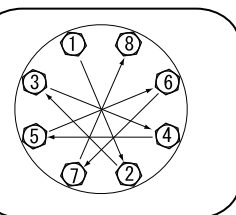



## **YAMADA AMERICA, INC**

955 E. ALGONQUIN RD., ARLINGTON HEIGHTS, IL 60005, USA  
PHONE: 1-847-631-9200 or 1-800-990-7867 (Toll Free)      FAX : 1-847-631-9273  
[www.yamadapump.com](http://www.yamadapump.com)

**Manufactured by:**

## **YAMADA CORPORATION**

International Department  
1-1-3 CHOME, MINAMI MAGOME, OHTA-KU, TOKYO, 143-8504, JAPAN  
PHONE : +81-(0)3-3777-0241      FAX : +81-(0)3-3777-0584

201010 NDP304M